

TECHNICAL BULLETIN



Product: Best Boy 4000®, Best Boy HP, Bad Boy®, & Bad Boy HP Spot Luminaires

Manufacturer: PRG

Subject: Gobo Assembly Instructions

Bulletin No: GBO-001

Date: 11-13-2013, Updated 3-15-2018

INTRODUCTION

Gobo Assembly Instructions

This bulletin contains assembly instructions for the Best Boy/HP & Bad Boy/HP Spot Luminaire gobos.

To remove and replace a gobo assembly in either luminaire, refer to the procedure found in its User Manual.

CAUTION: This procedure applies to PRG gobos. Gobos by other vendors may not include an artwork alignment mark. Extra care must be taken to ensure consistent alignment from gobo to gobo, especially if gobos are assembled in multiple batches and/or by different technicians.

Gobo Requirements

In order to ensure consistency across all vendors, the requirements for gobo material, gobo size, and image size are included in this bulletin. Refer to "[Gobo Specifications](#)" on page 5.

PARTS

Bad Boy, Bad Boy HP

Part #: 41.9812.4000 ASSY, GOBO, NO GLASS, BAD BOY

Includes:

Part #: 10.9812.0236 CLIP, GOBO

Part #: 22.9812.0241 ASSY, CARRIER W/BEARING

Part #: 55.6876.0001 MAGNET, .062 x .062 SAMARIUM COBALT MAGNETIZED

Best Boy, Best Boy HP

Part #: 41.9816.4000 ASSEMBLY, GOBO HOLDER, NO GLASS, BEST BOY

Includes:

Part #: 22.9816.0311 ASSY, ROTATING GOBO PLANET

Part #: 10.9816.0312 CLIP, GOBO BEST BOY

Part #: 55.6876.0001 MAGNET, .062 x .062 SAMARIUM COBALT MAGNETIZED

RTV 3145

Part #: 06.6083.0001.0 RTV, 3145 CLEAR 305ML CAULK TUBE

Part #: 06.6083.0090.0 RTV, 3145 CLEAR 90mL TUBE MIL-A-46146

Syringe

Part #: 06.3005.0001 SYRINGE, 10CC MANUAL

- Manufactured by KAHNETICS, Part # for 10 ml is M10LLASSM (This does not include the tip.)

Syringe Tip

Part #: 06.3028.0001.0 NEEDLE, TAPER TIP PINK 50/BAG

- Manufactured by Ellsworth Adhesives, Part # EA20GT-1 1/4

PROCEDURES

Gobo Assembly Instructions

Tools and Supplies

- Q-Tips
- Acetone or Isopropyl Alcohol
- RTV 3145 (with tapered needle-tip dispenser)

To assemble a gobo:

Step 1. Place gobo carrier on workbench with its gear side up as shown in **Figure 1**.

Step 2. Using a Q-Tip, clean inside ring of gobo carrier with acetone or alcohol. Allow to dry.

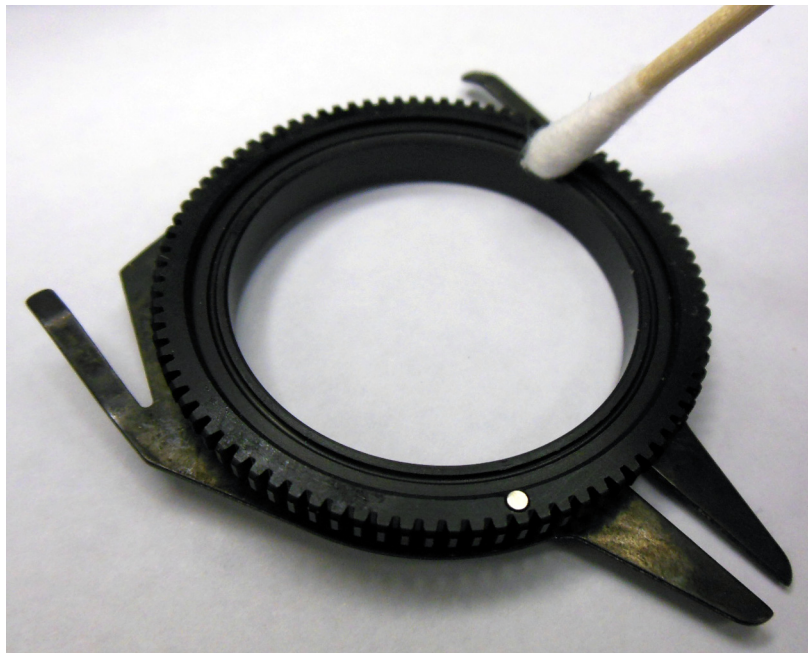

Figure 1: Cleaning Gobo Carrier

Step 3. Apply a ring of RTV 3145 in deepest groove of gobo carrier using a tapered needle-tip dispenser as shown in **Figure 2**.



Figure 2: Applying RTV

Step 4. Place glass in carrier, silver side down (black side up) as shown in **Figure 3**. If there is an alignment mark on the glass, align it with the carrier's magnet. (Gobos by other vendors may not include an alignment mark. Extra care must be taken to ensure consistent alignment from gobo to gobo.)

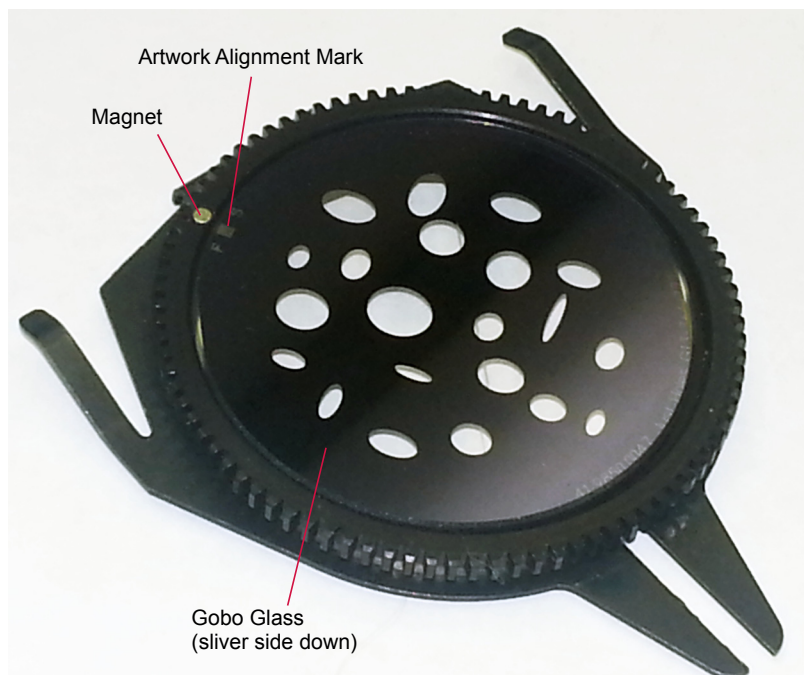

Figure 3: Installing Gobo Glass / Alignment

- Step 5. Using a Q-Tip, press perimeter edges of glass so that it fully seats into carrier as shown in **Figure 4**.
CAUTION: Do not press in the center area of the glass, as it may cause the glass to break.



Figure 4: Securing Glass in Carrier

- Step 6. Allow RTV to dry at least four (4) hours.
Step 7. Using wooden end of a Q-Tip, remove excess glue from glass as shown in **Figure 5**.
CAUTION: Failing to remove excess glue may result in a distorted image.

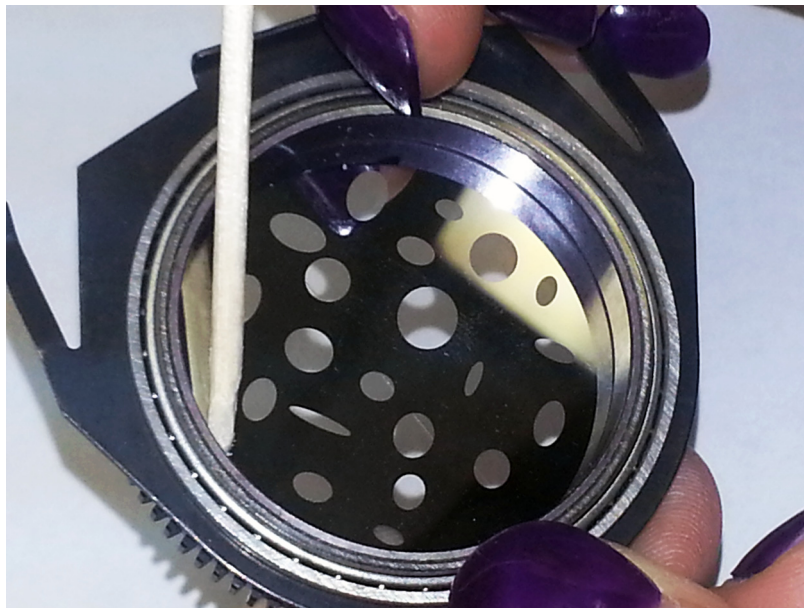

Figure 5: Removing Excess Glue

- Step 8. Verify that no adhesive is present in the teeth of the gears and that the gobo rotates freely.

GOBO SPECIFICATIONS

Bad Boy

MATERIAL: 1.1 mm FUSED SILICA – BACK/WHITE GOBOS
1.1 mm BOROSILICATE – COLOR GOBOS

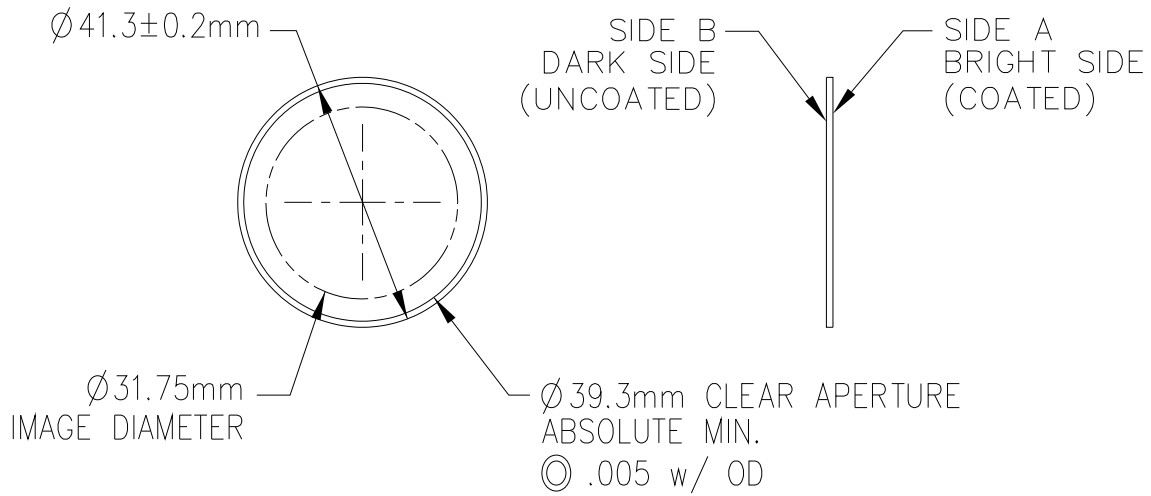

Figure 6: Bad Boy Gobo Blank

Best Boy

MATERIAL: 1.1mm BOROSILICATE

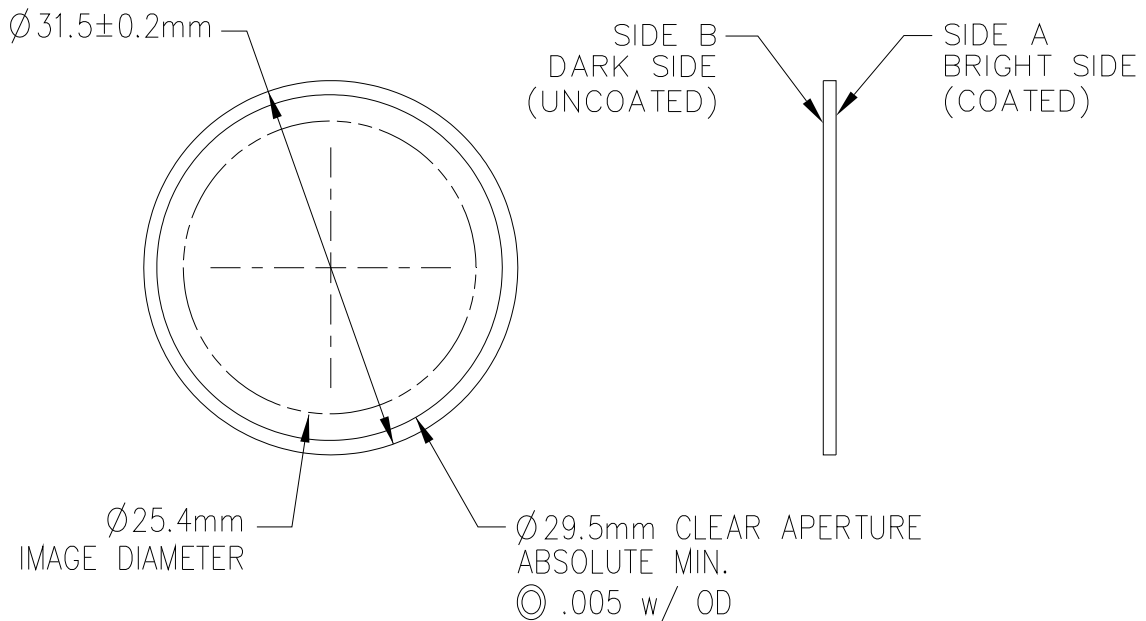

Figure 7: Best Boy Gobo Blank